

Homework #6: Chapters 13-15

The following exercises are due at the beginning of class on Monday, April 19. Note, this homework is continued on the reverse side of the paper.

1. [25 pts.] A full joint distribution for the Boolean random variables A , B , and C is specified below. Assume that the true value of a random variable is the corresponding lower case letter (e.g., $P(b)$ means $P(B=true)$).

	b		$\neg b$	
	c	$\neg c$	c	$\neg c$
a	0.01	0.20	0.10	0.25
$\neg a$	0.04	0.05	0.15	0.20

Use the distribution to compute the following probabilities and probability distribution. Show your work.

- $P(\neg b)$
 - $\mathbf{P}(C)$
 - $P(\neg a \wedge \neg b)$
 - $P(\neg c \vee a)$
 - $P(a \mid b \wedge \neg c)$
2. [20 pts.] Do exercise 14.2 (a-d) from the book (p. 533).
3. [30 pts.] Consider the Bayesian network in Figure 1 (on the next page), where A , B , C , and D are all Boolean random variables. Compute the following probabilities and probability distributions, using a $\langle \text{true}, \text{false} \rangle$ ordering for all Boolean variable probability distributions. You must give computed numeric answers and show all of your work.
- $P(a \wedge \neg b \wedge c \wedge d)$
 - $\mathbf{P}(A \mid b \wedge c \wedge \neg d)$
 - $\mathbf{P}(B \mid \neg c \wedge d)$
4. [25 pts.] Consider a simple game where a sub is moving in a 3x3 grid. Being on the surface, you cannot see the sub, but have a sonar that detects a ping at a specific location on each time step. At each time step, the sub moves to an adjacent square. The sub is equally likely to move to each legal (i.e., in bounds of the grid) square to the north, east, south, or west of its current location; and each legal diagonal square is half as likely as a move in one of the four compass points. Note, the sub only has 8 legal moves when it is in the center (location (2,2)), and could have as few as three legal moves when it is in a corner. The sub must move to a new square at each time step. The ping location for the sonar will be one square north, east, south, or west of the sub's true location with a 10% probability for each such legal adjacent square. Any other squares where the sub is not located will be the ping location with a 5% probability. Otherwise, the ping location will be the true location of the sub. Give a Bayesian network structure (similar to the one in Figure 15.2, p. 540) for this Markov process, including values for all relevant conditional probability tables. Use two discrete variables Sub_t and $Sonar_t$ to represent each state. The domain of both of these variables are the 9

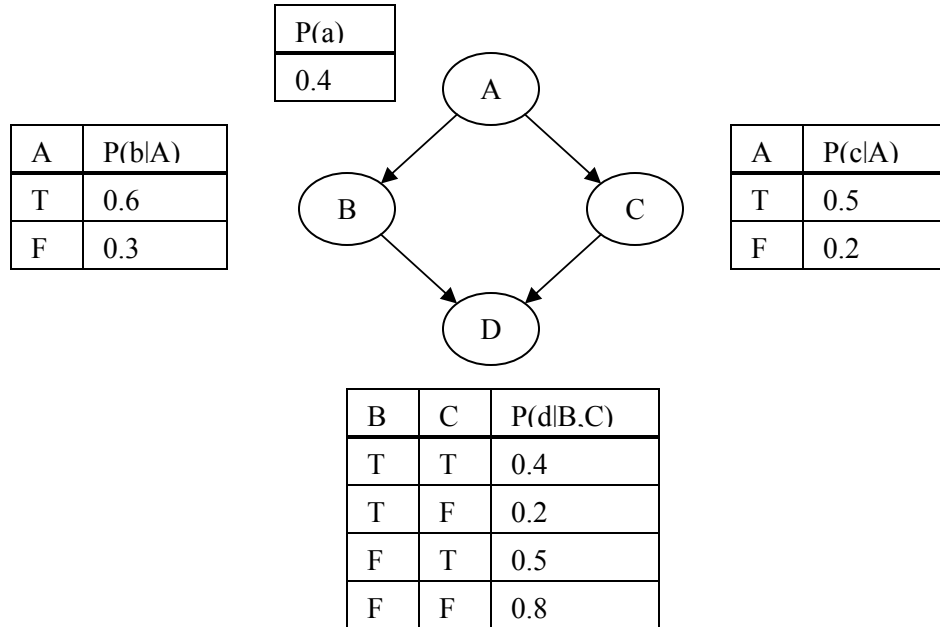

Figure 1. Bayesian Network for Problem #3

possible squares; identified by their (x,y) coordinates as $(1,1)$, $(1,2)$, $(1,3)$, $(2,1)$, $(2,2)$, $(2,3)$, $(3,1)$, $(3,2)$ and $(3,3)$.