

## Homework #6: Chapters 13, 14 and 16

The following exercises are due at the beginning of class on Wednesday, April 18. Note, there is an additional exercise on the back of this sheet.

1. [25 points] A full joint distribution for the Boolean random variables  $A$ ,  $B$ , and  $C$  is specified below. Use a <true,false> ordering for any Boolean variable probability distributions. Assume that the true value of a random variable is the corresponding lower case letter (e.g.,  $P(b)$  means  $P(B=true)$ )

	$b$		$\neg b$	
	$c$	$\neg c$	$c$	$\neg c$
$a$	0.01	0.30	0.10	0.20
$\neg a$	0.04	0.05	0.15	0.15

Use the distribution to compute the following probabilities and probability distribution. Show your work.

- $P(a)$
  - $P(C)$
  - $P(\neg a \wedge b)$
  - $P(\neg c \vee a)$
  - $P(a \mid \neg b \wedge c)$
2. [10 points] After your annual checkup, the doctor has bad news and good news. The bad news is that you tested positive for a serious disease and that the test is 99% accurate (i.e., the probability of testing positive when you do have the disease is 0.99, as is the probability of testing negative when you don't have the disease). The good news is that this is a rare disease, striking only 1 in 10,000 people of your age. Why is it good news that the disease is rare? What are the chances that you actually have the disease?
3. [20 points] A robot soccer player has the option to dribble, pass, or shoot on the goal. If the robot dribbles, there is a 0.2 probability that the other team will steal the ball; otherwise the robot keeps control of the ball. If the robot passes, there is a 0.2 probability that the other team will intercept the pass and a 0.1 probability that the ball will go out of bounds (giving control to the other team); otherwise the pass succeeds. If the robot shoots on the goal, there is a 0.2 probability that it will score, a 0.6 probability that it will be caught by the opponent's goalie, and a 0.2 probability that the shot will go out of bounds (note, in each of the last two situations the other team gains control of the ball). The utility of the robot maintaining control of the ball is 10, the utility of giving it to a teammate is 20, the utility of scoring a goal is 100, and the utility of losing the ball to the other team is -30.

What is the expected utility of each action? To maximize the chance for partial credit, be sure to show your work. If the agent follows the principle of maximum expected utility and only considers single actions (as opposed to action sequences), which action will it choose?

4. [45 points] Consider the Bayesian network below, where A, B, C, and D are all Boolean random variables.

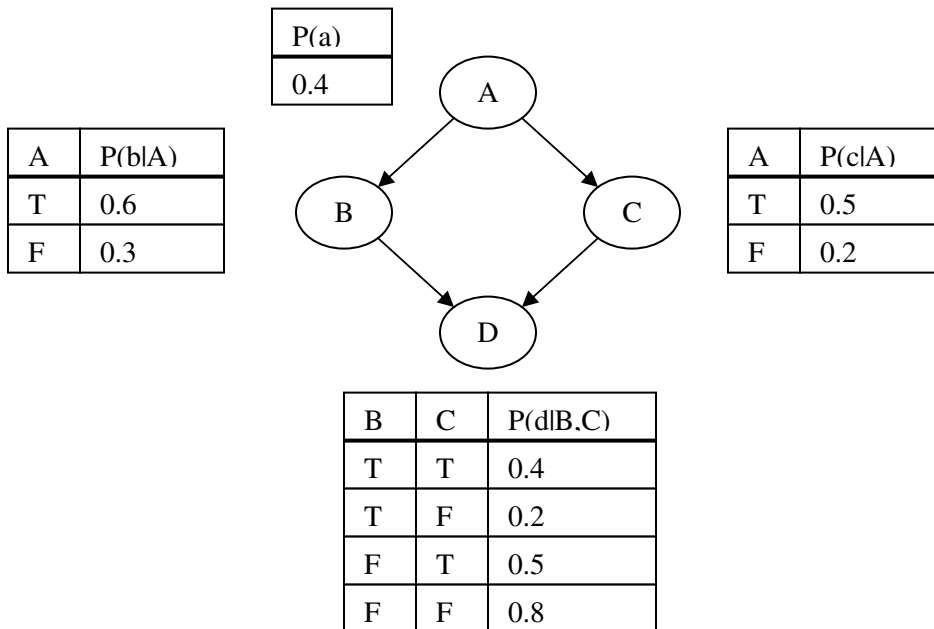

Compute the following probabilities and probability distributions. Always use a <true,false> ordering for Boolean variable probability distributions. You must give computed numeric answers and show all of your work.

- [10 points]  $P(a \wedge \neg b \wedge c \wedge d)$
- [15 points]  $\mathbf{P}(A \mid b \wedge c \wedge \neg d)$
- [20 points]  $\mathbf{P}(B \mid \neg c \wedge d)$