

22. Parts Orienting

Mechanics of Manipulation

Matt Mason

`matt.mason@cs.cmu.edu`

`http://www.cs.cmu.edu/~mason`

Carnegie Mellon

Chapter 1 Manipulation 1

- 1.1 Case 1: Manipulation by a human 1
- 1.2 Case 2: An automated assembly system 3
- 1.3 Issues in manipulation 5
- 1.4 A taxonomy of manipulation techniques 7
- 1.5 Bibliographic notes 8
- Exercises 8

Chapter 2 Kinematics 11

- 2.1 Preliminaries 11
- 2.2 Planar kinematics 15
- 2.3 Spherical kinematics 20
- 2.4 Spatial kinematics 22
- 2.5 Kinematic constraint 25
- 2.6 Kinematic mechanisms 34
- 2.7 Bibliographic notes 36
- Exercises 37

Chapter 3 Kinematic Representation 41

- 3.1 Representation of spatial rotations 41
- 3.2 Representation of spatial displacements 58
- 3.3 Kinematic constraints 68
- 3.4 Bibliographic notes 72
- Exercises 72

Chapter 4 Kinematic Manipulation 77

- 4.1 Path planning 77
- 4.2 Path planning for nonholonomic systems 84
- 4.3 Kinematic models of contact 86
- 4.4 Bibliographic notes 88
- Exercises 88

Chapter 5 Rigid Body Statics 93

- 5.1 Forces acting on rigid bodies 93
- 5.2 Polyhedral convex cones 99
- 5.3 Contact wrenches and wrench cones 102
- 5.4 Cones in velocity twist space 104
- 5.5 The oriented plane 105
- 5.6 Instantaneous centers and Reuleaux's method 109
- 5.7 Line of force; moment labeling 110
- 5.8 Force dual 112
- 5.9 Summary 117
- 5.10 Bibliographic notes 117
- Exercises 118

Chapter 6 Friction 121

- 6.1 Coulomb's Law 121
- 6.2 Single degree-of-freedom problems 123
- 6.3 Planar single contact problems 126
- 6.4 Graphical representation of friction cones 127
- 6.5 Static equilibrium problems 128
- 6.6 Planar sliding 130
- 6.7 Bibliographic notes 139
- Exercises 139

Chapter 7 Quasistatic Manipulation 143

- 7.1 Grasping and fixturing 143
- 7.2 Pushing 147
- 7.3 Stable pushing 153
- 7.4 Parts orienting 162
- 7.5 Assembly 168
- 7.6 Bibliographic notes 173
- Exercises 175

Chapter 8 Dynamics 181

- 8.1 Newton's laws 181
- 8.2 A particle in three dimensions 181
- 8.3 Moment of force; moment of momentum 183
- 8.4 Dynamics of a system of particles 184
- 8.5 Rigid body dynamics 186
- 8.6 The angular inertia matrix 189
- 8.7 Motion of a freely rotating body 195
- 8.8 Planar single contact problems 197
- 8.9 Graphical methods for the plane 203
- 8.10 Planar multiple-contact problems 205
- 8.11 Bibliographic notes 207
- Exercises 208

Chapter 9 Impact 211

- 9.1 A particle 211
- 9.2 Rigid body impact 217
- 9.3 Bibliographic notes 223
- Exercises 223

Chapter 10 Dynamic Manipulation 225

- 10.1 Quasidynamic manipulation 225
- 10.2 Briefly dynamic manipulation 229
- 10.3 Continuously dynamic manipulation 230
- 10.4 Bibliographic notes 232
- Exercises 235

Appendix A Infinity 237

Outline.

- Manufacturing
- Radius function and diameter function
- Push function
- Representing uncertainty
- Planning

Automation and parts orienting

Assembly systems need oriented parts

Recall SONY Smart cell and APOS

Most common example: bowl feeder

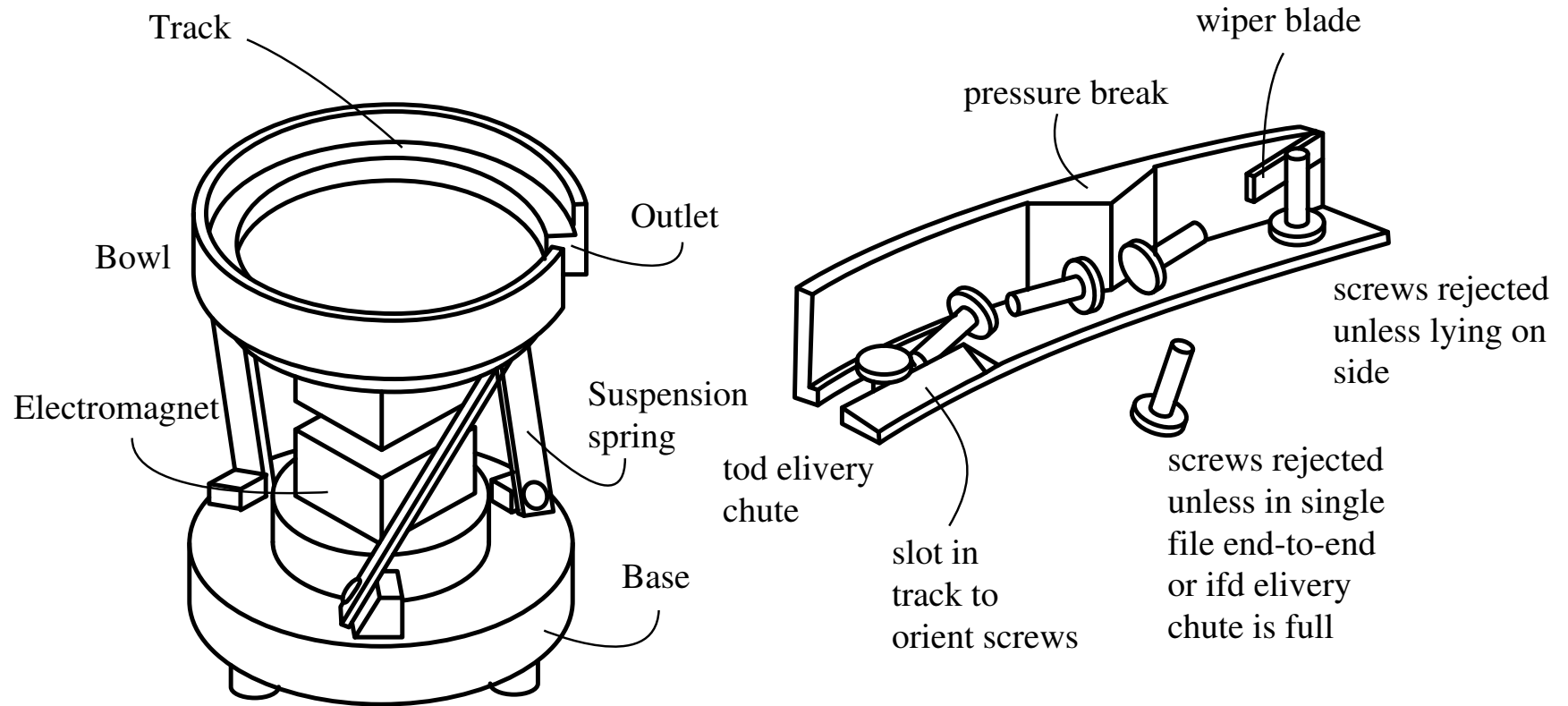

Orienting by pushing

Pushing is a good way to orient a part.

- Generic and flexible: with a flat support surface and a flat pusher, the same hardware can be used for a very broad variety of parts.
- An important problem: to find a sequence of motions that will orient a given part.

Assumptions

1. Isolated rigid planar polygon, on a planar support surface.
2. Coulomb's law, uniform coefficient of friction.
3. Square pushing: pusher translates along its normal.
4. The part makes contact only with the face of the pusher. Each push proceeds until the part reaches a stable orientation.
5. Quasistatic: a balance of contact forces and gravity determines the object motion with sufficient accuracy.

Radius function

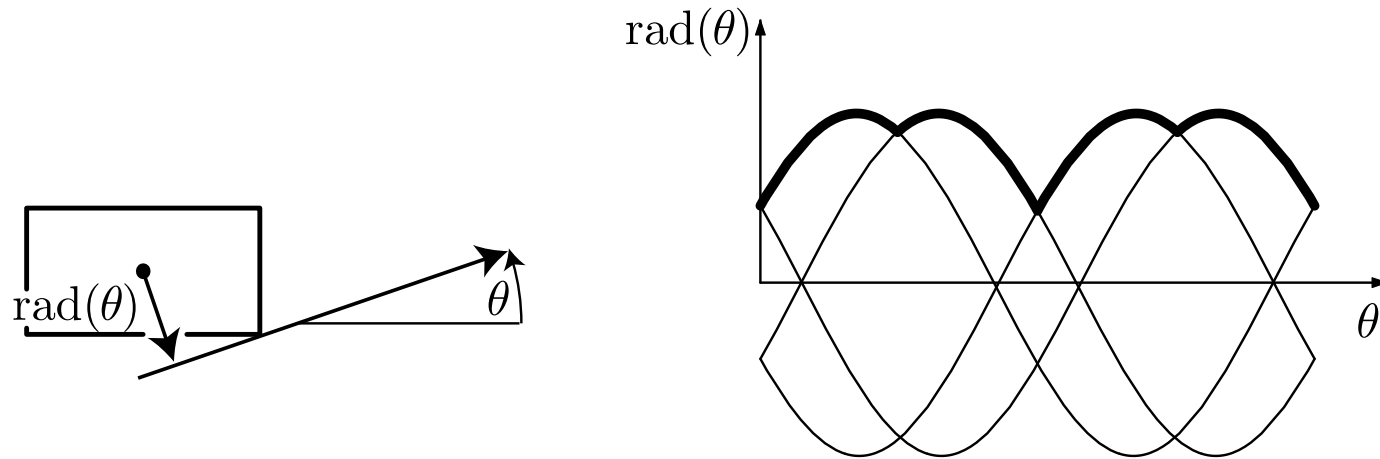

Definition of the radius function.

Square pushing and radius function

For square pushing, radius function behaves like a potential function.

- For a square push, the contact normal is the line of pushing, which splits the votes of the friction cone edges.
- So decision can switch when center of friction crosses contact normal (peak of radius function)
- ... or when we switch from one vertex to another (valley of radius function).

Push function

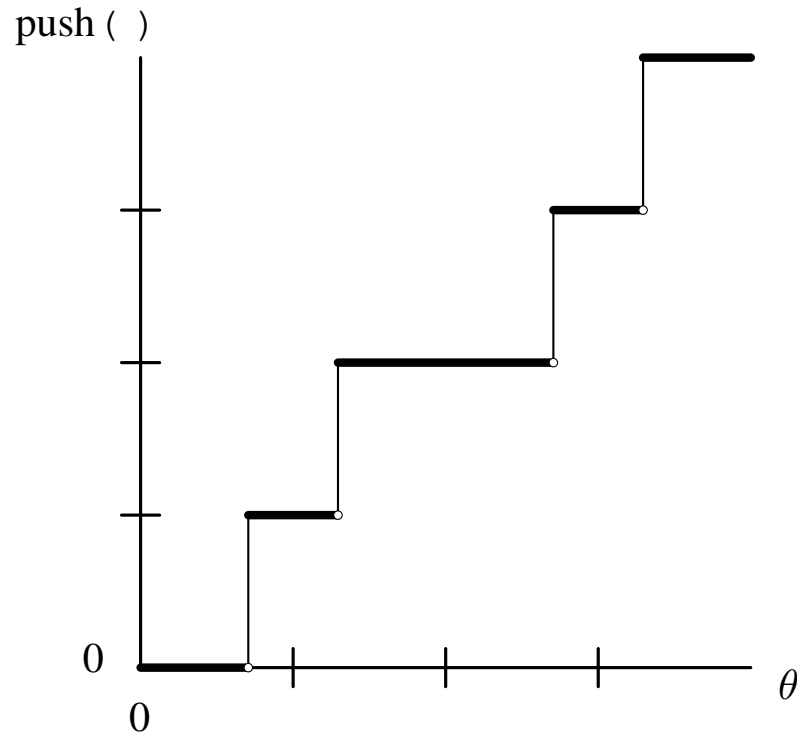

Define the push function mapping given object orientation θ to orientation resulting from square push.

Uncertainty

- The push function maps area between two maxes to a min.
- One push can eliminate a little bit of orientation uncertainty.
- Can a sequence of pushes eliminate a lot?

We represent uncertain orientation as a closed interval $\Theta = [\alpha, \beta]$. Define $\bar{p}(\Theta)$ to return the smallest interval containing $\{\text{push}(\theta) | \theta \in \Theta\}$.

Possibilism

Possibilistic approach: Representing uncertainty by set of possibilities.

Conservative approximation: approximating the set of the possible states by a superset. (A plan that works for the approximation will work for the actual possibilities.)

Sometimes probabilistic approach would be better.

Planning the last step

To plan *last* step of n -step plan:

- Θ_n : set of orientations before step n .
- What is the largest set that can be oriented in one push? I.e. what is the largest Θ such that $\bar{p}(\Theta)$ is a single point?

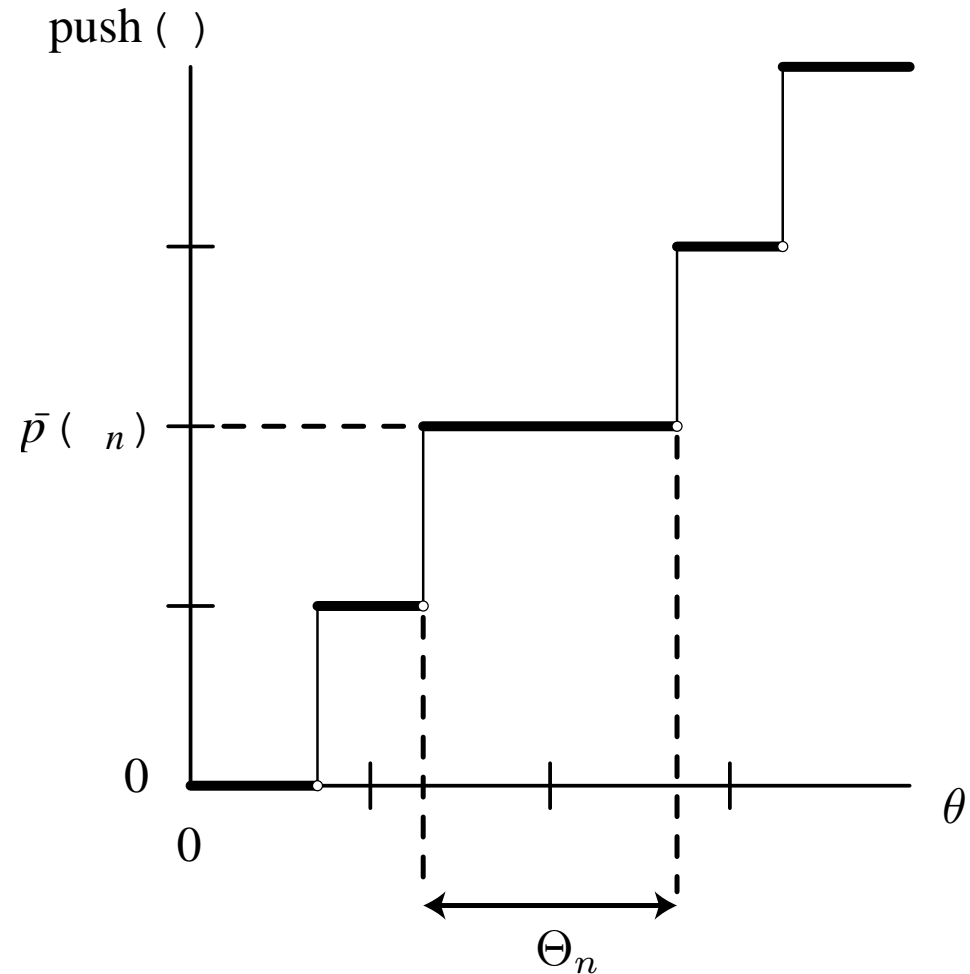

Planning the next-to-last step

- Result must be at least as large as Θ_n .
- To find Θ_{n-1} :
 - What is the largest interval Θ that can be oriented in two pushes? I.e. what is the largest Θ such that $\bar{p}(\Theta)$ is smaller than Θ_n ?

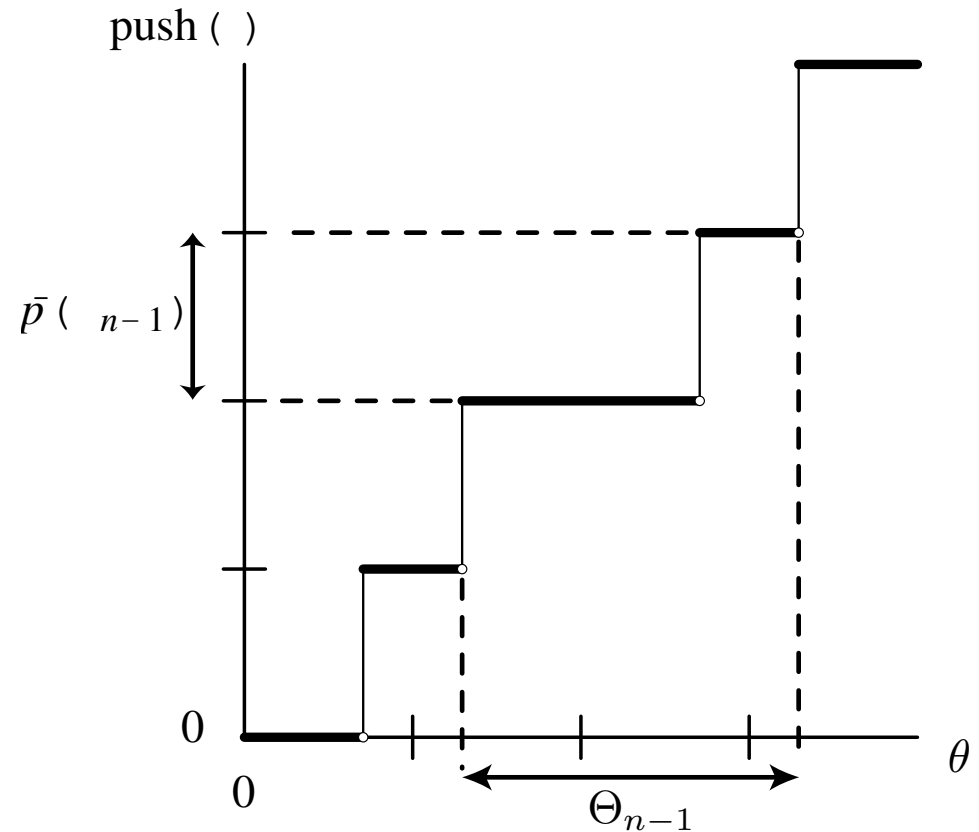

The planning algorithm

1. Construct the push function.
2. Find the widest step in the push function. Call it Θ_n , and set i to 1.
3. Set Θ_{n-i} to the largest interval Θ such that $|\bar{p}(\Theta)| < |\Theta_{n-i+1}|$. If $|\Theta_{n-i}| = |\Theta_{n-i+1}|$ then set n to i and terminate. Otherwise increment i and repeat step 3.

A theorem, without a proof

Theorem (Goldberg):

The algorithm produces plans that orient any planar polygon up to symmetry in the push function.

Related systems:

- Squeezing (Goldberg)
- Not-square pushing (Brost)
- Sequences of fences (Peshkin)
- 1JOC (Actuated fence over conveyor) (Akella et al)

Diatribes on factories and uncertainty

Some think there is no uncertainty in the factories. E.g., found on the web, <http://www.abc.net.au/rn/science/buzz/stories/s1130271.htm>): “Most of the robotic systems that are currently in industrial applications like factory automation, the primary objective is to minimise that uncertainty. So rather than making the robot smart enough to deal with the uncertainty you structure the environment so there is no uncertainty.”

Flame on:

1. Frustration. Some of us are interested in factory manipulation *specifically* because of uncertainty.
2. Which is the environment, and which the robot?
3. Even *after* parts oriented, uncertainty is central issue.
4. Perhaps the factory is *just* smart enough to deal with the uncertainty.
5. Still there is a difference between factories and museum tour guides. The best word is not *uncertainty* but *unstructured*.

Sanderson: 1984 IEEE ICRA

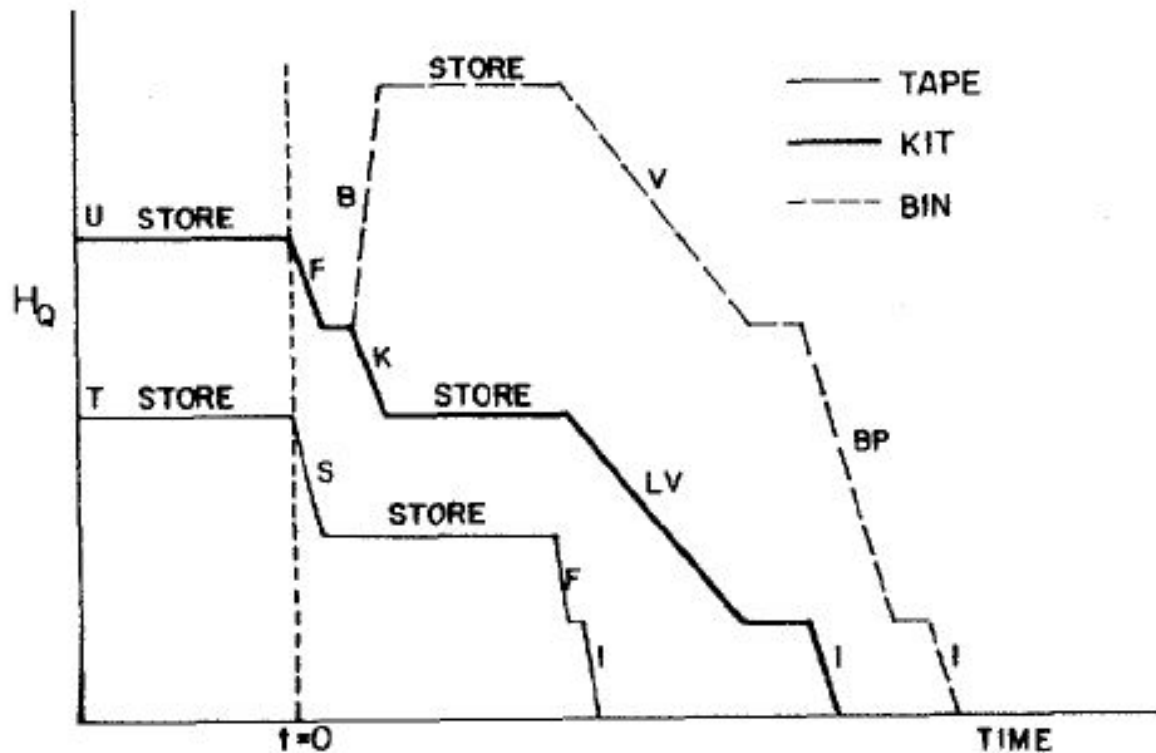

Figure 4-3: Parts entropy sequences for three different electronics assembly strategies:

- (1) Taped (T) and Sequenced (S) components, forming (F) and automatic insertion (I),
- (2) Formed (F), Kitted (K) components, lead visualization (LV), and insertion (I)
- (3) Formed (F), Binned (B) components, lead visualization (LV), and insertion (I)

Chapter 1 Manipulation 1

- 1.1 Case 1: Manipulation by a human 1
- 1.2 Case 2: An automated assembly system 3
- 1.3 Issues in manipulation 5
- 1.4 A taxonomy of manipulation techniques 7
- 1.5 Bibliographic notes 8
- Exercises 8

Chapter 2 Kinematics 11

- 2.1 Preliminaries 11
- 2.2 Planar kinematics 15
- 2.3 Spherical kinematics 20
- 2.4 Spatial kinematics 22
- 2.5 Kinematic constraint 25
- 2.6 Kinematic mechanisms 34
- 2.7 Bibliographic notes 36
- Exercises 37

Chapter 3 Kinematic Representation 41

- 3.1 Representation of spatial rotations 41
- 3.2 Representation of spatial displacements 58
- 3.3 Kinematic constraints 68
- 3.4 Bibliographic notes 72
- Exercises 72

Chapter 4 Kinematic Manipulation 77

- 4.1 Path planning 77
- 4.2 Path planning for nonholonomic systems 84
- 4.3 Kinematic models of contact 86
- 4.4 Bibliographic notes 88
- Exercises 88

Chapter 5 Rigid Body Statics 93

- 5.1 Forces acting on rigid bodies 93
- 5.2 Polyhedral convex cones 99
- 5.3 Contact wrenches and wrench cones 102
- 5.4 Cones in velocity twist space 104
- 5.5 The oriented plane 105
- 5.6 Instantaneous centers and Reuleaux's method 109
- 5.7 Line of force; moment labeling 110
- 5.8 Force dual 112
- 5.9 Summary 117
- 5.10 Bibliographic notes 117
- Exercises 118

Chapter 6 Friction 121

- 6.1 Coulomb's Law 121
- 6.2 Single degree-of-freedom problems 123
- 6.3 Planar single contact problems 126
- 6.4 Graphical representation of friction cones 127
- 6.5 Static equilibrium problems 128
- 6.6 Planar sliding 130
- 6.7 Bibliographic notes 139
- Exercises 139

Chapter 7 Quasistatic Manipulation 143

- 7.1 Grasping and fixturing 143
- 7.2 Pushing 147
- 7.3 Stable pushing 153
- 7.4 Parts orienting 162
- 7.5 Assembly 168
- 7.6 Bibliographic notes 173
- Exercises 175

Chapter 8 Dynamics 181

- 8.1 Newton's laws 181
- 8.2 A particle in three dimensions 181
- 8.3 Moment of force; moment of momentum 183
- 8.4 Dynamics of a system of particles 184
- 8.5 Rigid body dynamics 186
- 8.6 The angular inertia matrix 189
- 8.7 Motion of a freely rotating body 195
- 8.8 Planar single contact problems 197
- 8.9 Graphical methods for the plane 203
- 8.10 Planar multiple-contact problems 205
- 8.11 Bibliographic notes 207
- Exercises 208

Chapter 9 Impact 211

- 9.1 A particle 211
- 9.2 Rigid body impact 217
- 9.3 Bibliographic notes 223
- Exercises 223

Chapter 10 Dynamic Manipulation 225

- 10.1 Quasidynamic manipulation 225
- 10.2 Briefly dynamic manipulation 229
- 10.3 Continuously dynamic manipulation 230
- 10.4 Bibliographic notes 232
- Exercises 235

Appendix A Infinity 237